

35, 50 LLC (1)

RECORDED IN OFFICIAL RECORDS
INSTRUMENT # 2005201150 4 PGS
2005 SEP 07 03:08 PM
KAREN E. RUSHING
CLERK OF THE CIRCUIT COURT
SARASOTA COUNTY, FLORIDA
MTAYLOR Receipt#682002

This Instrument Prepared By:
Margaret S. Frook, Esquire
BOONE, BOONE, BOONE, KODA & FROOK, P.A.
P.O. Box 1596
Venice, Florida 34284



**SIXTH AMENDMENT TO DECLARATION OF CONDOMINIUM OF
MIRABELLA, A CONDOMINIUM**

MIRABELLA CONDOMINIUMS, LLC, a Florida limited liability company (hereinafter "Developer"), pursuant to Section 5.2 of the Declaration of Condominium of Mirabella, a Condominium, as recorded in Official Records Instrument #2005008122, public records of Sarasota County, Florida, as amended (the "Declaration"), does hereby amend the Declaration, as follows:

The Surveyor's Certificate indicating the substantial completion of Building #3 of Phase 2 (containing Units 3101, 3102, 3201, 3202, 3301, 3302, 3401, and 3402) is attached hereto and incorporated herein.

All other provisions of the above-described Declaration, as amended, shall remain in full force and effect. This Amendment is made and entered into this 25th day of August, 2005.

Witnesses:

MIRABELLA CONDOMINIUMS, LLC, a Florida limited liability company

Sign Tammy Lindemuth
Print Tammy Lindemuth

By [Signature]
Michael W. Miller, as Managing Member

Sign [Signature]
Print Wayne A. Burda

STATE OF FLORIDA
COUNTY OF SARASOTA

I HEREBY CERTIFY that the foregoing Amendment to Declaration of Condominium was acknowledged before me this 25 day of August, 2005, by Michael W. Miller, as Managing Member of MIRABELLA CONDOMINIUMS, LLC, a Florida limited liability company, on behalf of the company. He is personally known to me or produced known as identification.

(SEAL) My Commission Expires:

Tammy D. Lindemuth
Commission #DD146195
Expires: Aug 29, 2006
Bonded Thru
Atlantic Bonding Co., Inc.

NOTARY PUBLIC
Sign Tammy Lindemuth
Print Tammy Lindemuth

CERTIFICATE OF SURVEYOR

I, the undersigned Registered Surveyor & Mapper, hereby certify as follows:

1. This certificate is made with respect to the following Condominium: "MIRABELLA" A CONDOMINIUM, as per the plat recorded in Condominium Book 37, Pages 25-25C, Public records of Sarasota County, Florida. This Certificate involves Units 3101-3102, 3201-3202, 3301-3302, 3401-3402, within said Condominium, Building 3, Phase 2.
2. The construction of the improvements within said Condominium pertaining to the respective Units is substantially complete.
3. The plat (as amended by the pages attached hereto, if applicable) together with the provisions of the Declaration describing the Condominium property, recorded in official record instrument number 2005008122 of the public records of Sarasota County, Florida, is an accurate representation of the locations and dimensions of Building 3 and Units therein.
4. The identification, location and dimensions of the common elements and of each Unit can be determined from the plat, as hereby amended, and the provisions of said Declaration.
5. All planned improvements, including, but not limited to, landscaping, utility services and access to said Units, and the common element facilities serving the Units, and the Building in which the Units are located, have been substantially completed.
6. Sheet 3 of 4, Page 25-B, of the Recorded Plat of "MIRABELLA" A Condominium, as per the plat recorded in Condominium Book 37, Pages 25-25C, Public records of Sarasota County, Florida, has been modified to indicate unit interior layout adjustments. Sheet 4 of 4, Page 25-C, of said Plat, has been modified to add a typical cross section of Building 3. The cross section shows the upper units of Building 3, and the vertical heights of the vaulted ceilings. The modified pages are attached hereto.

Strayer Surveying & Mapping, Inc.
Licensed Surveyor Business No. 6639

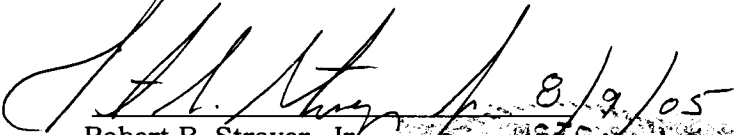
Robert B. Strayer, Jr.
FL Surveyor Certificate No. 5027

Strayer Surveying & Mapping, Inc.
763 Shamrock Blvd.
Venice, FL 34293
Ph. (941) 497-1290

Date: 8/09/05
Page 1 of 3

MIRABELLA
A CONDOMINIUM
LYING IN SECTION 10, TOWNSHIP 39 SOUTH, RANGE 19 EAST
CITY OF VENICE, SARASOTA COUNTY, FLORIDA

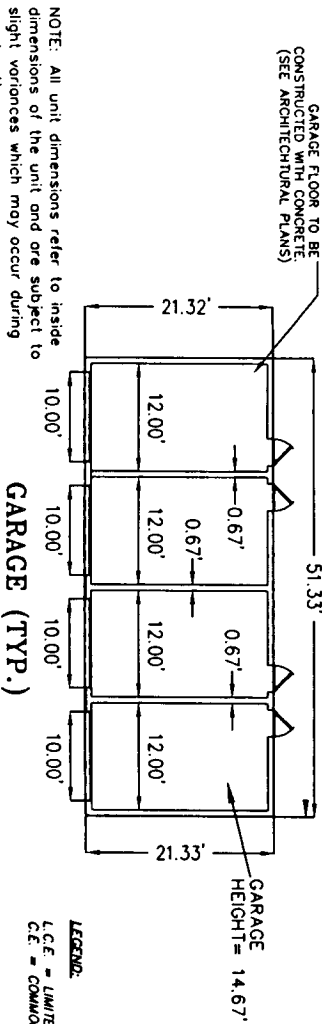
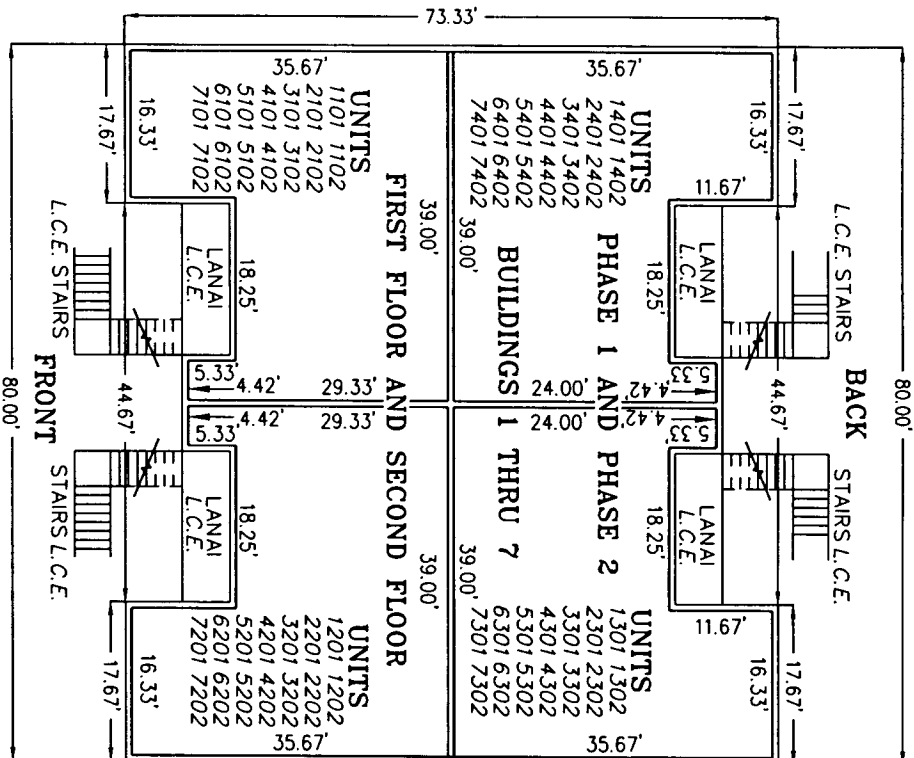
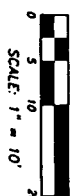

SURVEYOR'S NOTES:
UNIT BOUNDARIES: EACH UNIT SHALL INCLUDE THAT PART OF THE BUILDING CONTAINING THE UNIT THAT LIES WITHIN THE FOLLOWING BOUNDARIES:
(A) **UPPER AND LOWER BOUNDARIES:** THE UPPER AND LOWER BOUNDARIES OF THE UNIT SHALL BE THE FOLLOWING BOUNDARIES EXTENDED TO THEIR PLANAR INTERSECTIONS WITH THE PERIMETRICAL BOUNDARIES:
(1) **UPPER BOUNDARIES:** THE HORIZONTAL PLANE OF THE UNFINISHED LOWER SURFACE OF THE CEILING
(2) **LOWER BOUNDARIES:** THE HORIZONTAL PLANE OF THE UNFINISHED UPPER SURFACE

(B) **PERIMETRICAL BOUNDARIES:** THE PERIMETRICAL BOUNDARIES OF THE UNIT SHALL BE THE VERTICAL PLANES OF THE UNFINISHED INTERIOR SURFACES OF THE WALLS BOUNDING THE UNIT EXTENDED TO THEIR PLANAR INTERSECTIONS WITH EACH OTHER AND WITH THE UPPER AND LOWER BOUNDARIES.
(C) **APERTURES:** WHERE THERE ARE APERTURES IN ANY BOUNDARY INCLUDING BUT NOT LIMITED TO WINDOWS (AND OTHER TYPES) AND SLIDING GLASS DOORS BUT DOES INCLUDE GLASS CURTAIN WALLS) AND EXTEND TO THE EXTERIOR SURFACE OF SLIDING GLASS DOORS AND UNFINISHED EXTERIOR SURFACES OF EXTERIOR DOORS. THE FRAMEWORK FOR WINDOWS (AGAIN NOT INCLUDING FRAMEWORK FOR SLIDING GLASS DOORS) SHALL NOT BE INCLUDED IN THE BOUNDARIES OF THE UNIT AND SHALL BE COMMON ELEMENTS.

(D) **UTILITY EQUIPMENT AND CONDUITS:** THE UNITS SHALL INCLUDE ALL PLUMBING AND ELECTRICAL EQUIPMENT AND CONDUITS LOCATED WITHIN THE BOUNDARIES OF THE UNIT EXCEPT WHERE THE PLUMBING AND ELECTRICAL AND OTHER UTILITY LINES WITHIN THE COMMON ELEMENTS WHICH SERVE THE UNIT ONLY. THE UNIT SHALL NOT INCLUDE ELECTRICAL AND PLUMBING LINES, CONDUITS, EQUIPMENT, FIXTURES, PIPES, WIRES, AIR PASSAGEWAYS, DUCTS, OR OTHER UTILITY LINES RUNNING THROUGH OR ADJACENT TO THE UNIT WHICH ARE UTILIZED FOR OR SERVE ANOTHER ELEMENT.
(E) **AIR CONDITIONING/HEATING:** ANY AIR CONDITIONING/HEATING EQUIPMENT WHICH SERVES ONLY A SINGLE UNIT SHALL BE CONSIDERED PART OF SAID UNIT AND NOT A COMMON ELEMENT.

(F) **APPLIANCES:** THE UNIT OWNER SHALL OWN ANY ELECTRIC DOORBELL/SKINCKERS, HOT WATER HEATERS, REFRIGERATORS, DISHWASHERS, ELECTRIC GARAGE DOOR OPENERS, GARAGE DOORS, AND OTHER APPLIANCES WHICH ARE LOCATED WITHIN THE BOUNDARIES OF THE UNIT OR THE LIMITED COMMON ELEMENTS.
(G) **FIXTURES:** THE UNIT OWNER SHALL OWN ALL INTERIOR FIXTURES WHICH SHALL SERVE THE UNIT EXCLUSIVELY, INCLUDING WITHOUT LIMITATION, ALL PLUMBING FIXTURES, UTILITY AND ELECTRICAL FIXTURES AND CABINETS.

(H) **EXCEPTIONS:** IN CASES NOT SPECIFICALLY COVERED ABOVE, AND/OR IN ANY CASE OF CONFLICT OR AMBIGUITY, THE SURVEY OF THE UNITS SET FORTH AS EXHIBIT "A" HERETO SHALL CONTROL IN DETERMINING THE BOUNDARIES OF A UNIT, EXCEPT THAT THE PROVISIONS OF SECTION 3.3(C) ABOVE SHALL CONTROL UNLESS SPECIFICALLY DEPICTED OTHERWISE ON SUCH SURVEY.
(I) **LIMITED COMMON ELEMENTS:** ASSIGNED PARKING SPACES, AND LANAI AREAS ARE LIMITED COMMON ELEMENTS.

(J) **COMMON ELEMENTS:** THE SIDEWALKS, UNASSIGNED PARKING SPACES, CLUB HOUSE AND POOL AS DEPICTED ON THE SURVEY AND PLOT PLAN ARE COMMON ELEMENTS, WITH THE EXCEPTION OF ASSIGNED PARKING SPACES.

NOTES:
ARCHITECTURAL DRAWINGS WERE PROVIDED BY WATERFORD HOMES DATED 8-27-03. REFER TO THE FULL SET OF ARCHITECTURAL DRAWINGS FOR INDIVIDUAL INTERNAL UNIT DIMENSIONS, LAYOUT, AND CEILING.

LEGEND:
L.C.E. = LIMITED COMMON ELEMENT
C.E. = COMMON ELEMENT

Stroyer Surveying & Mapping, Inc.
763 Shamrock Boulevard Venice, Florida 34293
(941) 496-9488 Fax (941) 497-6186
335 Tamiami Trail Port Charlotte, Florida 33953
(941) 624-4900 Fax (941) 624-3471
e-mail address - stroyersurveying@comcast.net

NOTE: All unit dimensions refer to inside dimensions of the unit and are subject to slight variances which may occur during construction.

MIRABELLA

A CONDOMINIUM

LYING IN SECTION 10, TOWNSHIP 39 SOUTH, RANGE 19 EAST
CITY OF VENICE, SARASOTA COUNTY, FLORIDA

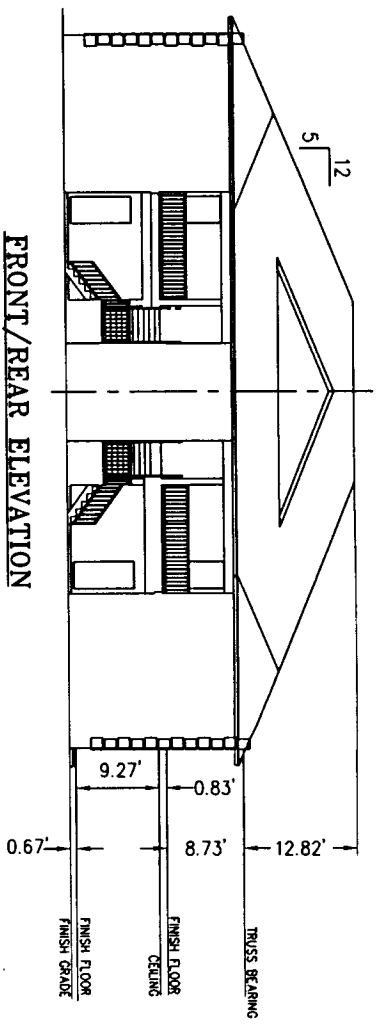
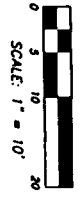

SURVEYOR'S NOTES:
UNIT BOUNDARIES: EACH UNIT SHALL INCLUDE THAT PART OF THE BUILDING CONTAINING THE UNIT THAT LIES WITHIN THE FOLLOWING BOUNDARIES:
(A) UPPER AND LOWER BOUNDARIES: THE UPPER AND LOWER BOUNDARIES OF THE UNIT SHALL BE THE FOLLOWING BOUNDARIES EXTENDED TO THEIR PLANAR INTERSECTIONS WITH THE PERIMETRICAL BOUNDARIES:

- (1) UPPER BOUNDARIES: THE HORIZONTAL PLANE OF THE UNFINISHED LOWER SURFACE OF THE CEILING
- (II) LOWER BOUNDARIES: THE HORIZONTAL PLANE OF THE UNFINISHED UPPER SURFACE OF THE FLOOR OF THE UNIT
- (B) PERIMETRICAL BOUNDARIES: THE PERIMETRICAL BOUNDARIES OF THE UNIT SHALL BE THE UNFINISHED INTERIOR SURFACES OF THE WALLS BOUNDING THE UNIT EXTENDED TO THEIR PLANAR INTERSECTIONS WITH EACH OTHER AND WITH THE UPPER AND LOWER BOUNDARIES
- (C) APERTURES: WHERE THERE ARE APERTURES IN ANY BOUNDARY, INCLUDING, BUT NOT LIMITED TO, WINDOWS AND DOORS, THE BOUNDARIES OF THE UNIT EXTEND TO THE FINISH SURFACE OF ALL WINDOWS (WHICH TERM DOES NOT INCLUDE SLIDING SURFACE OF SLIDING GLASS DOORS AND GLASS CURTAIN WALLS) AND EXTEND TO THE EXTERIOR SURFACE OF SLIDING GLASS DOORS AND UNFINISHED EXTERIOR SURFACES OF EXTERIOR DOORS. THE FRAMEWORK FOR WINDOWS (AGAIN NOT INCLUDING FRAMEWORK FOR SLIDING GLASS DOORS) SHALL NOT BE INCLUDED IN THE BOUNDARIES OF THE UNIT AND SHALL BE COMMON ELEMENTS.
- (D) UTILITY EQUIPMENT AND FIXTURES: THE UNITS SHALL INCLUDE ALL PLUMBING AND ELECTRICAL LINES, EQUIPMENT AND FIXTURES LOCATED WITHIN THE BOUNDARIES OF THE UNIT WHICH SERVE THE UNIT ONLY. THESE INCLUDE, BUT ARE NOT LIMITED TO, THE COMMON ELEMENTS WHICH SERVE THE UNIT ONLY, THESE INCLUDE ELECTRICAL AND PLUMBING LINES, CONDENSERS, EQUIPMENT, FIXTURES, WRETS, AIR PASSAGEWAYS, DUCTS, OR OTHER UTILITY LINES RUNNING THROUGH OR ADJACENT TO THE UNIT WHICH ARE UTILIZED FOR OR SERVE ANOTHER UNIT OR THE COMMON ELEMENTS, WHICH ITEMS SHALL BE MADE A PART OF THE COMMON ELEMENTS.
- (E) AIR CONDITIONING/ELECTRICAL: ANY AIR CONDITIONING/ELECTRICAL EQUIPMENT WHICH SERVICES ONLY A SINGLE UNIT SHALL BE CONSIDERED PART OF SAID UNIT AND NOT A COMMON ELEMENT.
- (F) APPLIANCES: THE UNIT OWNER SHALL OWN ALL ELECTRIC DOORBELLS/BELLCHANGERS, HOT WATER HEATERS, REFRIGERATORS, DISHWASHERS, ELECTRIC GARAGE DOOR OPENERS, GARAGE DOORS, AND OTHER APPLIANCES WHICH ARE LOCATED WITHIN THE BOUNDARIES OF THE UNIT OR THE LIMITED COMMON ELEMENTS.
- (G) FIXTURES: THE UNIT OWNER SHALL OWN ALL INTERIOR FIXTURES WHICH SHALL SERVE THE UNIT EXCLUSIVELY, INCLUDING WITHOUT LIMITATION, ALL PLUMBING FIXTURES, UTILITY AND ELECTRICAL FIXTURES AND CABINETS.
- (H) EXCEPTIONS: IN CASES NOT SPECIFICALLY COVERED ABOVE, AND/OR IN ANY CASE OF CONFLICT DETERMINING THE BOUNDARIES OF A UNIT, EXCEPT THAT THE PROVISIONS OF SECTION 3.3(C) ABOVE SHALL CONTROL UNLESS SPECIFICALLY OTHERWISE ON SUCH SURVEY.
- (I) LIMITED COMMON ELEMENTS: ASSIGNED PARKING SPACES, AND LAWN AREAS ARE LIMITED COMMON ELEMENTS.
- (J) COMMON ELEMENTS: THE SIDEWALKS, UNASSIGNED PARKING SPACES, CLUB HOUSE AND POOL AS DEPICTED ON THE SURVEY AND PLOT PLAN ARE COMMON ELEMENTS, WITH THE EXCEPTION OF ASSIGNED PARKING SPACES.

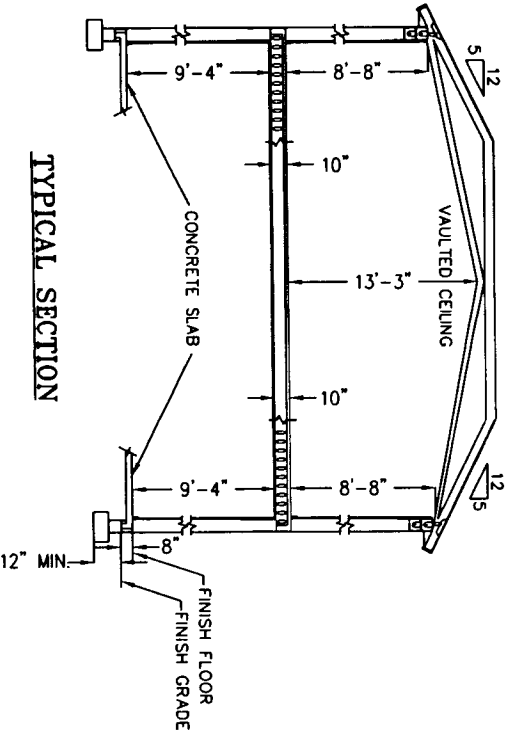

NOTE:
ARCHITECTURAL DRAWINGS WERE PROVIDED BY WATERFORD HOMES DATED 6-27-03. REFER TO THE FULL SET OF ARCHITECTURAL DRAWINGS FOR INDIVIDUAL INTERNAL UNIT DIMENSIONS AND LAYOUT.

NOTE: All unit dimensions refer to inside dimensions of the unit and are subject to slight variances which may occur during construction.

Stroyer Surveying & Mapping, Inc.

763 Shamrock Boulevard
Venice, Florida 34293
(941) 496-9488
Fax (941) 497-6186
e-mail address - stroyersurveying@comcast.net

335 Tamiami Trail
Port Charlotte, Florida 33953
(941) 624-4900
Fax (941) 624-3471